

www.wackergroup.com

0154635en	005
1106	

Rammer

BS 600

BS 700

OPERATOR'S MANUAL

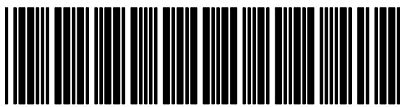

0 1 5 4 6 3 5 E N

1. Foreword	3
2. Emission Control System Information	4
3. Safety Information	10
3.1 Operating Safety	11
3.2 Operator Safety while using Internal Combustion Engines	12
3.3 Service Safety	13
3.4 Label Locations	14
3.5 Safety Labels	15
3.6 Operating Labels	18
4. Technical Data	20
4.1 Rammer	20
4.2 Sound Measurements	21
4.3 Vibration Measurements	21
4.4 Dimensions	21
5. Operation	22
5.1 Application	22
5.2 Recommended Fuel	22
5.3 Before Starting	22
5.4 To Start	23
5.5 To Stop	24
5.6 Operation	24
5.7 Proper Compaction	25

6. Maintenance	26
6.1 Periodic Maintenance Schedule	26
6.2 Air Cleaner	27
6.3 Lubrication	28
6.4 Shoe Hardware	28
6.5 Carburetor Adjustments	29
6.6 Storage	29
6.7 Transportation	30
6.8 Troubleshooting	31

CALIFORNIA

Proposition 65 Warning:



Engine exhaust, some of its constituents, and certain vehicle components, contain or emit chemicals known to the State of California to cause cancer and birth defects or other reproductive harm.

1. Foreword

This manual provides information and procedures to safely operate and maintain this Wacker model. For your own safety and protection from injury, carefully read, understand and observe the safety instructions described in this manual.

Keep this manual or a copy of it with the machine. If you lose this manual or need an additional copy, please contact Wacker Corporation. This machine is built with user safety in mind; however, it can present hazards if improperly operated and serviced. Follow operating instructions carefully! If you have questions about operating or servicing this equipment, please contact Wacker Corporation.

The information contained in this manual was based on machines in production at the time of publication. Wacker Corporation reserves the right to change any portion of this information without notice.

All rights, especially copying and distribution rights, are reserved.

Copyright 2006 by Wacker Corporation.

No part of this publication may be reproduced in any form or by any means, electronic or mechanical, including photocopying, without express written permission from Wacker Corporation.

Any type of reproduction or distribution not authorized by Wacker Corporation represents an infringement of valid copyrights and will be prosecuted. We expressly reserve the right to make technical modifications, even without due notice, which aim at improving our machines or their safety standards.

Emission Control System Information

2. Emission Control System Information

Source of Emissions

The combustion process produces carbon monoxide, oxides of nitrogen, and hydrocarbons. Control of hydrocarbons and oxides of nitrogen is very important because, under certain conditions, they react to form photochemical smog when subjected to sunlight. Carbon monoxide does not react in the same way, but it is toxic.

Wacker utilizes lean carburetor settings and other systems to reduce the emissions of carbon monoxide, oxides of nitrogen, and hydrocarbons.

The U.S. and California Clean Air Acts

EPA and California regulations require all manufacturers to furnish written instructions describing the operation and maintenance of emission control systems.

The following instructions and procedures must be followed in order to keep the emissions from your Wacker engine within the emissions standards.

Tampering and Altering

Tampering with or altering the emission control system may increase emissions beyond the legal limit. Among those acts that constitute tampering are:

- Removal or alteration of any part of the intake, fuel, or exhaust systems.
- Altering or defeating the speed-adjusting mechanism to cause the engine to operate outside its design parameters.

Problems That May Affect Emissions

If you are aware of any of the following symptoms, have your engine inspected and repaired by your servicing dealer.

- Hard starting or stalling after starting.
- Rough idle.
- Misfiring or backfiring under load.
- Afterburning (backfiring).
- Black exhaust smoke or high fuel consumption.

Emission Control System Information

Replacement Parts

The emission control systems on your Wacker engine were designed, built, and certified to conform with EPA and California emissions regulations. We recommend the use of genuine Wacker parts whenever you have maintenance done. These original-design replacement parts are manufactured to the same standards as the original parts, so you can be confident of their performance. The use of replacement parts that are not of the original design and quality may impair the effectiveness of your emission control system.

A manufacturer of an aftermarket part assumes the responsibility that the part will not adversely affect emission performance. The manufacturer or rebuilder of the part must certify that use of the part will not result in a failure of the engine to comply with emission regulations.

Maintenance

Follow the maintenance schedule. Remember that this schedule is based on the assumption that your machine will be used for its designed purpose. Sustained high-load or high-temperature operation, or use in unusually wet or dusty conditions, will require more frequent service.

OXYGENATED FUELS

Some conventional gasolines are being blended with alcohol or an ether compound. These gasolines are collectively referred to as oxygenated fuels. To meet clean air standards, some areas of the United States and Canada use oxygenated fuels to help reduce emissions.

If you use an oxygenated fuel, be sure it is unleaded and meets the minimum octane rating requirement.

Before using an oxygenated fuel, try to confirm the fuel's contents. Some States / Provinces require this information to be posted on the pump.

The following are EPA-approved percentages of oxygenates:

ETHANOL - (ethyl or grain alcohol) 10% by volume. You may use gasoline containing up to 10% ethanol by volume. Gasoline containing ethanol may be marketed under the name "Gasohol".

MTBE - (methyl tertiary butyl ether) 15% by volume. You may use gasoline containing up to 15% MTBE by volume.

Emission Control System Information

METHANOL - (methyl or wood alcohol) 5% by volume. You may use gasoline containing up to 5% methanol by volume, as long as it contains cosolvents and corrosion inhibitors to protect the fuel system. Gasoline containing more than 5% methanol by volume may cause starting and/or performance problems. It may also damage metal, rubber, and plastic parts of your fuel system.

If you notice any undesirable operating symptoms, try another service station, or switch to another brand of gasoline.

Fuel system damage or performance problems resulting from the use of an oxygenated fuel containing more than the percentages of oxygenates mentioned above are not covered under warranty.

Emission Control System Warranty

Your new Wacker engine complies with the U.S. EPA emissions regulations. Wacker provides the same emission warranty coverage for engines sold in all 50 states.

YOUR WARRANTY RIGHTS AND OBLIGATIONS

All States

Wacker must warrant the emission control system on your engine for the period of time listed below provided there has been no abuse, neglect or improper maintenance of your engine. Where a warrantable condition exists, Wacker will repair your engine at no cost to you including diagnosis, parts and labor.

Your emission control system may include such parts as the carburetor, the ignition system and the catalytic converter.

Also included may be hoses, connectors and other emission-related assemblies.

MANUFACTURER'S WARRANTY COVERAGE:

The 1998 and later engines are warranted for two years. If any emission-related part on your engine is defective, the part will be repaired or replaced by Wacker.

Emission Control System Information

OWNER'S WARRANTY RESPONSIBILITY:

As the engine owner, you are responsible for the performance of the required maintenance listed in your owner's manual. Wacker recommends that you retain all receipts covering maintenance on your engine, but Wacker cannot deny warranty coverage solely for the lack of receipts or for your failure to ensure the performance of all scheduled maintenance.

As the engine owner, you should be aware that Wacker may deny you warranty coverage if your engine or a part has failed due to abuse, neglect, improper maintenance or unapproved modifications.

You are responsible for presenting your engine to a Wacker dealer as soon as a problem exists. The warranty repairs should be completed in a reasonable amount of time, not to exceed 30 days.

If you have any questions regarding your warranty rights and responsibilities, you should contact your local Wacker dealer.

WARRANTY COVERAGE:

Wacker engines sold after January 1, 1998, are covered by this Emission Control System Warranty for a period of two years from the date of delivery to the original retail purchaser. This warranty is transferable to each subsequent purchaser for the duration of the warranty period.

Warranty repairs will be made without charge for diagnosis, parts or labor. All defective parts replaced under this warranty become property of Wacker. A list of warranted parts is located on the next page. Normal maintenance items, such as spark plugs and filters, that are on the warranted parts list are warranted up to the required replacement interval only.

Wacker is also liable for damages to other engine components caused by a failure of any warranted parts during the warranty period.

Only Wacker approved replacement parts may be used in the performance of any warranty repairs and must be provided without charge to the owner. The use of replacement parts not equivalent to the original parts may impair the effectiveness of your engine emission control system. If such a replacement part is used in the repair or maintenance of your engine, and an authorized Wacker dealer determines it is defective or causes a failure of a warranted part, your claim for repair of your engine may be denied. If the part in question is not related to the reason your engine requires repair, your claim will not be denied.

Emission Control System Information

TO OBTAIN WARRANTY SERVICE:

You must take your Wacker product along with proof of original purchase date, at your expense, to any Wacker authorized dealer during their normal business hours. Claims for repair or adjustment found to be caused solely by defects in material or workmanship will not be denied because the engine was not properly maintained and used.

EXCLUSIONS:

FAILURES OTHER THAN THOSE RESULTING FROM DEFECTS IN MATERIAL OR WORKMANSHIP ARE NOT COVERED BY THIS WARRANTY. THIS WARRANTY DOES NOT EXTEND TO EMISSION CONTROL SYSTEMS OR PARTS WHICH ARE AFFECTED OR DAMAGED BY OWNER ABUSE, NEGLIGENCE, IMPROPER MAINTENANCE, MISUSE, MISFUELING, IMPROPER STORAGE, ACCIDENT AND/OR COLLISION, THE INCORPORATION OF, OR ANY USE OF, ANY ADD-ON OR MODIFIED PARTS, UNSUITABLE ATTACHMENTS, OR THE UNAUTHORIZED ALTERATION OF ANY PART.

THIS WARRANTY DOES NOT COVER REPLACEMENT OF EXPENDABLE MAINTENANCE ITEMS MADE IN CONNECTION WITH REQUIRED MAINTENANCE SERVICES AFTER THE ITEM'S FIRST SCHEDULED REPLACEMENT AS LISTED IN THE MAINTENANCE SECTION OF THE PRODUCT OWNER'S MANUAL, SUCH AS SPARK PLUGS AND FILTERS.

DISCLAIMER OF CONSEQUENTIAL DAMAGE AND LIMITATIONS OF IMPLIED WARRANTIES:

WACKER DISCLAIMS ANY RESPONSIBILITY FOR INCIDENTAL OR CONSEQUENTIAL DAMAGES SUCH AS LOSS OF TIME OR THE USE OF THE POWER EQUIPMENT, OR ANY COMMERCIAL LOSS DUE TO THE FAILURE OF THE EQUIPMENT; AND ANY IMPLIED WARRANTIES ARE LIMITED TO THE DURATION OF THIS WRITTEN WARRANTY. THIS WARRANTY IS APPLICABLE ONLY WHERE THE U.S. EPA EMISSION CONTROL SYSTEM WARRANTY REGULATION IS IN EFFECT.

Emission Control System Information

SYSTEMS COVERED BY THIS WARRANTY	PARTS DESCRIPTIONS
FUEL METERING	CARBURETOR ASSEMBLY
EXHAUST SYSTEM	MUFFLER
AIR INDUCTION	AIR FILTER HOUSING AIR FILTER ELEMENT*
IGNITION	FLYWHEEL MAGNETO IGNITION MODULE SPARK PLUG CAP SPARK PLUG*
MISCELLANEOUS PARTS	TUBING, FITTINGS, SEALS, GASKETS AND CLAMPS ASSOCIATED WITH THESE LISTED ITEMS
* Indicates expendable maintenance items.	

3. Safety Information

This manual contains DANGER, WARNING, CAUTION, *NOTICE* and NOTE callouts which must be followed to reduce the possibility of personal injury, damage to the equipment, or improper service.



This is the safety alert symbol. It is used to alert you to potential personal injury hazards. Obey all safety messages that follow this symbol to avoid possible injury or death.



DANGER

DANGER indicates a hazardous situation which, if not avoided, will result in death or serious injury.



WARNING

WARNING indicates a hazardous situation which, if not avoided, could result in death or serious injury.



CAUTION

CAUTION indicates a hazardous situation which, if not avoided, could result in minor or moderate injury.

NOTICE: Used without the safety alert symbol, **NOTICE** indicates a hazardous situation which, if not avoided, could result in property damage

Note: *Contains additional information important to a procedure.*

3.1 Operating Safety



Familiarity and proper training are required for the safe operation of equipment. Equipment operated improperly or by untrained personnel can be dangerous. Read the operating instructions contained in both this manual and the engine manual and familiarize yourself with the location and proper use of all controls. Inexperienced operators should receive instruction from someone familiar with the equipment before being allowed to operate the machine.

- 3.1.1 NEVER operate this machine in applications for which it is not intended.
- 3.1.2 NEVER allow anyone to operate this equipment without proper training. People operating this equipment must be familiar with the risks and hazards associated with it.
- 3.1.3 NEVER touch the engine or muffler while the engine is on or immediately after it has been turned off. These areas get hot and may cause burns.
- 3.1.4 NEVER use accessories or attachments that are not recommended by Wacker. Damage to equipment and injury to the user may result.
- 3.1.5 NEVER leave machine running unattended.
- 3.1.6 NEVER tamper with or disable the function of operating controls.
- 3.1.7 NEVER use choke to stop engine.
- 3.1.8 NEVER operate the machine in areas where explosions may occur.
- 3.1.9 ALWAYS read, understand, and follow procedures in the Operator's Manual before attempting to operate the equipment.
- 3.1.10 ALWAYS be sure that all other persons are at a safe distance from the machine. Stop the machine if people step into the working area of the machine.
- 3.1.11 ALWAYS be sure operator is familiar with proper safety precautions and operation techniques before using machine.
- 3.1.12 ALWAYS wear protective clothing appropriate to the job site when operating equipment.
- 3.1.13 ALWAYS wear hearing protection when operating equipment.
- 3.1.14 ALWAYS keep hands, feet, and loose clothing away from moving parts of the machine.
- 3.1.15 ALWAYS use common sense and caution when operating the machine.
- 3.1.16 ALWAYS be sure the rammer will not tip over, roll, slide, or fall when not being operated.
- 3.1.17 ALWAYS turn the engine OFF when the rammer is not being operated.

- 3.1.18 ALWAYS guide the rammer in such a way that the operator is not squeezed between the rammer and solid objects. Special care is required when working on uneven ground or when compacting coarse material. Make sure to stand firmly when operating the machine under such conditions.
- 3.1.19 ALWAYS operate the rammer in such a way that there is no danger of it turning over or falling in, when working near the edges of breaks, pits, slopes, trenches and platforms.
- 3.1.20 ALWAYS store the equipment properly when it is not being used. Equipment should be stored in a clean, dry location out of the reach of children.
- 3.1.21 ALWAYS close fuel valve on engines equipped with one when machine is not being operated.
- 3.1.22 ALWAYS operate machine with all safety devices and guards in place and in working order. DO NOT modify or defeat safety devices. DO NOT operate machine if any safety devices or guards are missing or inoperative.

3.2 Operator Safety while using Internal Combustion Engines



DANGER

Internal combustion engines present special hazards during operation and fueling. Read and follow the warning instructions in the engine owner's manual and the safety guidelines below. Failure to follow the warnings and safety guidelines could result in severe injury or death.

- 3.2.1 DO NOT smoke while operating the machine.
- 3.2.2 DO NOT smoke when refueling the engine.
- 3.2.3 DO NOT refuel a hot or running engine.
- 3.2.4 DO NOT refuel the engine near an open flame.
- 3.2.5 DO NOT spill fuel when refueling the engine.
- 3.2.6 DO NOT run the engine near open flames.
- 3.2.7 DO NOT run the machine indoors or in an enclosed area such as a deep trench unless adequate ventilation, through such items as exhaust fans or hoses, is provided. Exhaust gas from the engine contains poisonous carbon monoxide gas; exposure to carbon monoxide can cause loss of consciousness and may lead to death.
- 3.2.8 ALWAYS refill the fuel tank in a well-ventilated area.
- 3.2.9 ALWAYS replace the fuel tank cap after refueling.
- 3.2.10 ALWAYS check the fuel lines and the fuel tank for leaks and cracks before starting the engine. Do not run the machine if fuel leaks are present or the fuel lines are loose.

3.3 Service Safety





**WARNING**





Poorly maintained equipment can become a safety hazard! In order for the equipment to operate safely and properly over a long period of time, periodic maintenance and occasional repairs are necessary.

- 3.3.1 DO NOT attempt to clean or service the machine while it is running. Rotating parts can cause severe injury.
- 3.3.2 DO NOT operate the machine without an air cleaner.
- 3.3.3 DO NOT remove air cleaner cover, paper element, or precleaner while engine is running.
- 3.3.4 DO NOT alter engine speeds. Run the engine only at speeds specified in the Technical Data Section.
- 3.3.5 ALWAYS replace worn or damaged components with spare parts designed and recommended by Wacker Corporation.
- 3.3.6 DO NOT crank a flooded engine with the spark plug removed on gasoline-powered engines. Fuel trapped in the cylinder will squirt out the spark plug opening.
- 3.3.7 DO NOT test for spark on gasoline-powered engines if the engine is flooded or the smell of gasoline is present. A stray spark could ignite the fumes.
- 3.3.8 DO NOT use gasoline or other types of fuels or flammable solvents to clean parts, especially in enclosed areas. Fumes from fuels and solvents can become explosive.
- 3.3.9 ALWAYS replace the safety devices and guards after repairs and maintenance.
- 3.3.10 ALWAYS keep the area around the muffler free of debris such as leaves, paper, cartons, etc. A hot muffler could ignite the debris and start a fire.
- 3.3.11 ALWAYS do Periodic Maintenance as recommended in the Operator's Manual.
- 3.3.12 ALWAYS clean debris from engine cooling fins.
- 3.3.13 ALWAYS disconnect the spark plug on machines equipped with gasoline engines, before servicing, to avoid accidental start-up.
- 3.3.14 ALWAYS keep the machine clean and labels legible. Replace all missing and hard-to-read labels. Labels provide important operating instructions and warn of dangers and hazards.

3.5 Safety Labels



Wacker machines use international pictorial labels where needed. These labels are described below:



Label	Meaning
	<p>This molded-in label contains important safety and operating information. If it becomes illegible, the cover must be replaced. Refer to the Parts Book for ordering information.</p>
	<p>DANGER! Engines emit carbon monoxide; operate only in well-ventilated area.</p>
	<p>Read the operator's manual for machine information.</p>
	<p>DANGER! No sparks, flames or burning objects near machine.</p>
	<p>Shut off the engine before refueling.</p>

Label	Meaning
	<p>CAUTION! Use only clean, filtered gasoline fuel.</p>
	<p>WARNING! To prevent hearing loss, wear hearing protection when operating this machine.</p>
	<p>WARNING! Hot surface! Replace guard!</p>
	<p>WARNING! Serious injury if struck by compressed spring or cover. If the spring system cover is removed improperly, the springs can eject.</p>
	<p>Guaranteed sound power level in dB(A)</p>

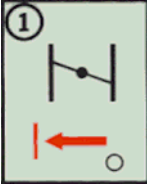
3.6 Operating Labels

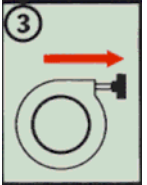
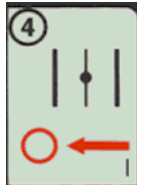
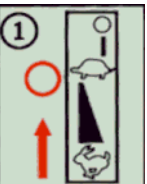
Wacker machines use international pictorial labels where needed. These labels are described below:

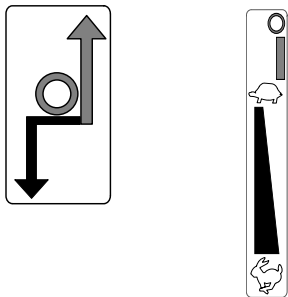
Label	Meaning
	<p>Close the choke.</p>
	<p>Place the throttle control lever in the “start” position.</p>
	<p>Pull the rewind starter.</p>
	<p>Open the choke.</p>
	<p>Place the throttle control lever in the “stop” position.</p>

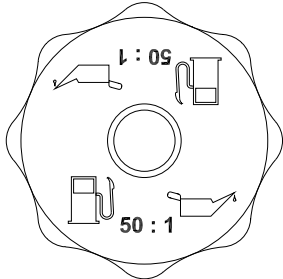
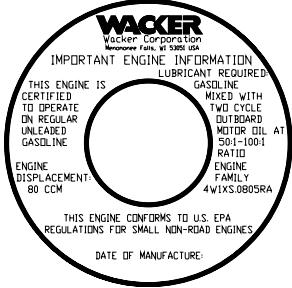
Label	Meaning
	<p>Throttle control lever: 0 = Stop</p> <p>Turtle = Start or Idle</p> <p>Rabbit = Full or Fast</p>
	<p>Engine stop button: Press to stop engine.</p>
	<p>Choke: 0 = Open</p> <p>I = Closed</p>
	<p>This rammer engine requires a two-cycle gasoline/oil mixture. Mix regular unleaded gasoline and two-cycle/outboard motor oil in separate container before filling tank.</p>
	

4. Technical Data

4.1 Rammer

Item Number:		BS 600 0007551, 0008207 0009076, 0009307	BS 700 0007552, 0008051 0008052, 0009308
Rammer			
Engine Model	type	WM80	
Engine Speed - full	rpm	4350 ± 100	
Engine Speed - idle	rpm	1800 ± 100	
Clutch Engagement	rpm	2800 ± 100	
Spark Plug	type	Champion RL95YC	
Electrode Gap	mm (in.)	0.8–0.9 (0.035)	
Cylinder Head Compression (cold)	bar/cm ³ (psi)	8.0–9.7 (120–140)	
Air Cleaner	type	Dual Element	
Engine Lubrication	oil grade	With standard two-cycle oil - use 50:1 ratio. With Wacker two-cycle or two-cycle oil per NMMA TC-W3, API TC, JASO FC or ISO EGD specifications - 100:1 or 50:1 ratio.	
Ramming System Lubrication	oil grade	SAE 10W30	
Ramming System Capacity	ml (oz.)	890 (30)	

4.2 Sound Measurements

Die gemäß Abschnitt 1.7.4.f der 89/392/EG-Maschinenrichtlinie geforderte Geräuschangabe beträgt für

- den Schalldruckpegel am Bedienerplatz (L_{pA}) = 90 dB(A)
- den Garantierte Schallleistungspegel (L_{WA}) = 108 dB(A).

Diese Geräuschwerte wurden nach ISO 3744 für den Schalleistungspegel (L_{WA}) bzw. ISO 6081 für den Schalldruckpegel (L_{pA}) am Bedienerplatz ermittelt.

4.3 Vibration Measurements

The operating hand/arm vibration level, measured per the requirements of enclosure 1, Paragraph 2.2 or 3.6.3 of the EC-Machine Regulations, is approximately 15 m/s^2 .

The weighted effective acceleration value was determined according to ISO 8662 Part 1.

The sound and vibration measurements were obtained with the machine operating on crushed gravel at nominal engine speed.

4.4 Dimensions

mm (in.)

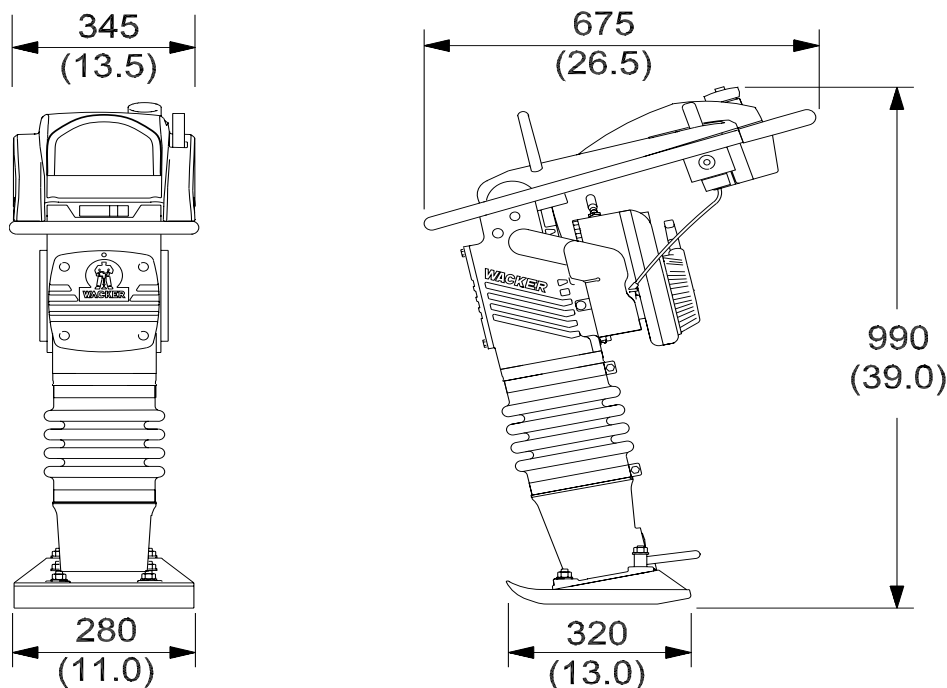

wc_gr000052

5. Operation

5.1 Application

Rammers are designed to compact loose soils and gravel to prevent settling and to provide a firm, solid base for the placement of footings, concrete slabs, foundations, and other structures.

5.2 Recommended Fuel

This rammer engine requires a two-cycle gasoline/oil mixture. Mix regular unleaded gasoline and two-cycle/outboard motor oil in separate container before filling tank.

FUEL RATIO 50:1				FUEL RATIO 100:1			
Gasoline	Oil	Gasoline	Oil	Gasoline	Oil	Gasoline	Oil
5 liters	100 ml	1 gallon	2.5 oz.	5 liters	50 ml	1 gallon	1.75 oz.
10 liters	200 ml	3 gallons	8.0 oz.	10 liters	100 ml	3 gallons	4.0 oz.
15 liters	300 ml	5 gallons	13.0 oz.	15 liters	150 ml	5 gallons	6.5 oz.

5.3 Before Starting

- 5.3.1 Read safety instructions at the beginning of this manual.
- 5.3.2 Fill tank with proper fuel mixture.
- 5.3.3 Place rammer on loose soil or gravel. DO NOT start rammer on hard surfaces such as asphalt or concrete.

5.4 To Start

See Graphic: *wc_gr000053*

5.4.1 Open fuel valve.

5.4.2 If the engine is cold, close choke (**b1**) on the carburetor.

Note: Occasionally, warm engines will need to be choked.

5.4.3 Move throttle control to $\frac{1}{4}$ to $\frac{1}{2}$ of the full position (**c3**).

5.4.4 Pull the starter rope (**a**) until the engine starts, or attempts to start.

Note: First time use, engines recently serviced, run out of fuel or not used for long periods of time may need the rope to be pulled more times to move fuel to the carburetor.

5.4.5 Open choke (**b2**) on the carburetor as the engine warms up, or, if it attempts to start, continue pulling the rope until it starts.

Note: A cold engine should be allowed to warm up at the idle position (**c2**) for approximately one (1) minute. Failure to open the choke after the engine attempts to start may cause flooding.

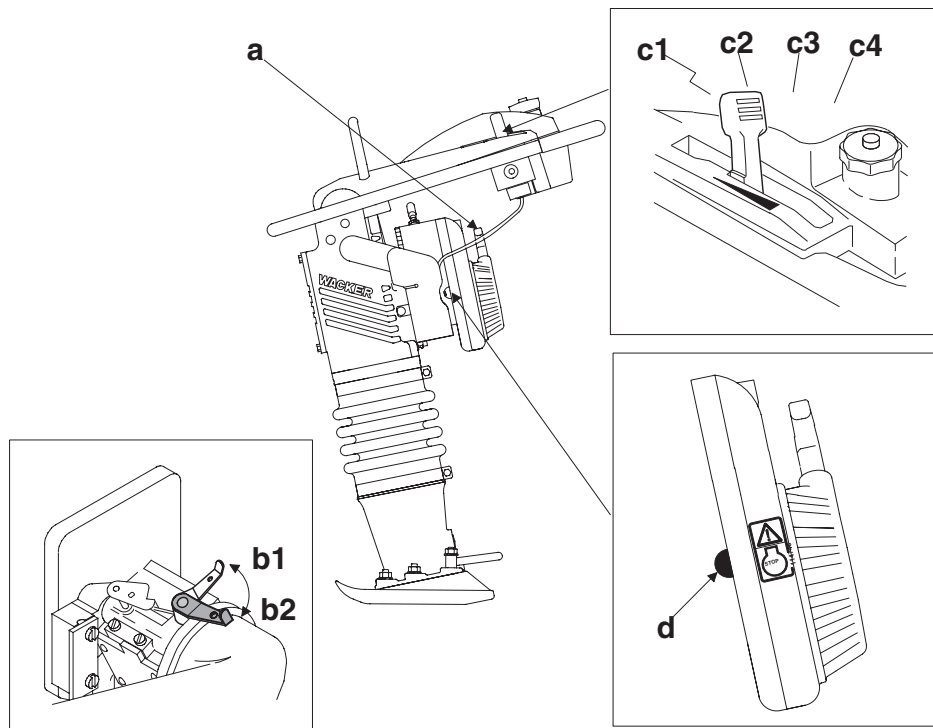

wc_gr000053

5.5 To Stop

See Graphic: *wc_gr000053*

- 5.5.1 Place throttle in the idle position **(c2)**.
- 5.5.2 Shut off the engine by moving the throttle through the detent to the off position **(c1)**. The engine will stop and the fuel valve will close.

Note: *If the throttle control wire should break, shut off the rammer manually by using the engine STOP button **(d)**.*

5.6 Operation

See Graphic: *wc_gr000044*

Keep vibratory rammer clean and dry. Avoid no-load strokes. Never allow the rammer to run full throttle when forcing away material or when lifting the equipment.

For optimal control, performance, and minimal hand/arm vibration, grasp handle as shown. Hand/arm vibration (HAV) has been optimized for this positioning. Reported HAV levels are measured at position **A** just in front of the hand position shown in conformance with EN1033 and ISO 5349.

NOTICE: To prevent damage to the rammer, do not allow the rammer to run on its side.

If the rammer should tip on its side, place the rammer in the position shown, then shut off the engine by moving the throttle control lever through the detent to the off position.

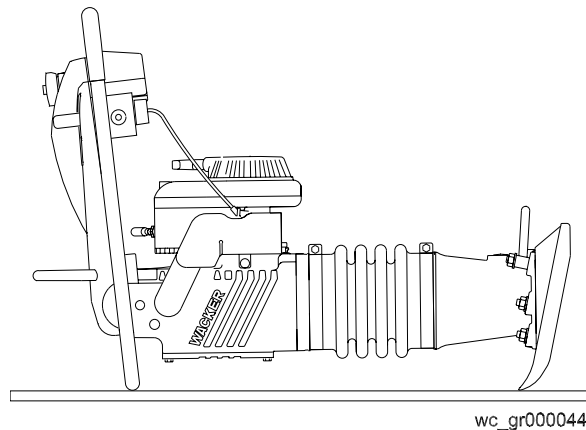

5.7 Proper Compaction

See Graphic: *wc_gr000045*

- 5.7.1 Run rammer at the full throttle position (**a4**) for maximum performance.
- 5.7.2 Guide rammer with its handle. Allow machine to pull itself forward. DO NOT try to over-power the machine.
- 5.7.3 For best compaction, the shoe must hit the ground flat (**b**), not on its toe or heel. This will save on excessive shoe wear.

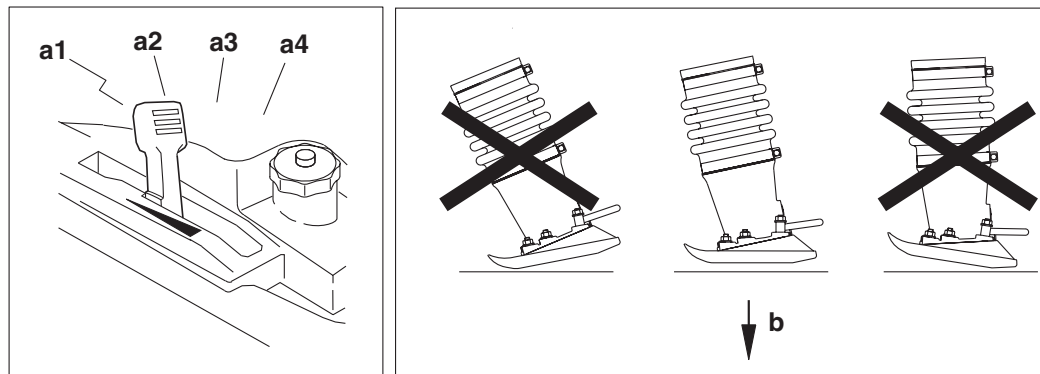

wc_gr000045

6. Maintenance

6.1 Periodic Maintenance Schedule

	Daily before starting	After first 5 hours	Every week or 25 hours	Every month or 100 hours	Every 3 months or 300 hours	Every Year
Check fuel level. Check engine oil level.	■					
Inspect air filter. Replace as needed.	■					
Check oil level in sightglass.	■					
Check fuel line and fittings for cracks or leaks. Replace as needed.	■					
Tighten ramming shoe hardware.		■	■			
Check external hardware.		■	■			
Clean engine cooling fins.			■			
Clean and check spark plug gap.			■			
Change engine oil.				■		
Replace spark plug.				■		
Clean recoil starter.					■	
Change ramming system oil.*					■	
Inspect crane lifting cable for wear, damage, or abuse.					■	
Inspect fuel filter.						■

* Change ramming system oil after first 50 hours of operation.
Note: If engine performance is poor, check, clean, and replace air filter elements as needed.

6.2 Air Cleaner

See Graphic: wc_gr000046



NEVER use gasoline or other types of low flash-point solvents for cleaning the air cleaner. A fire or explosion could result.

NOTICE: NEVER run engine without air cleaner. Severe engine damage will occur.

The rammer is equipped with a dual-element air cleaner. Under normal operating conditions, elements should be cleaned once every week. Under severe, dry and dusty conditions, the elements should be maintained daily. Replace an element when saturated with dirt that cannot be removed. Clean elements using the following procedure:

- 6.2.1 Remove air cleaner cover **(a)**. Remove precleaner and paper element and inspect them for holes or tears. Replace if damaged.
- 6.2.2 Precleaner **(b)**: Clean with low-pressure compressed air. When very soiled, wash in solution of mild detergent and warm water. Rinse thoroughly in clean water. Allow to dry thoroughly before re-installing.
Note: Do not oil precleaner.
- 6.2.3 Paper element **(c)**: Tap element lightly to remove excess dirt. Replace paper element if it appears heavily soiled.
- 6.2.4 Wipe out filter housing **(d)** with a clean cloth.

NOTICE: Do not allow dirt to get into the engine intake port while cleaning—damage to the engine will result.

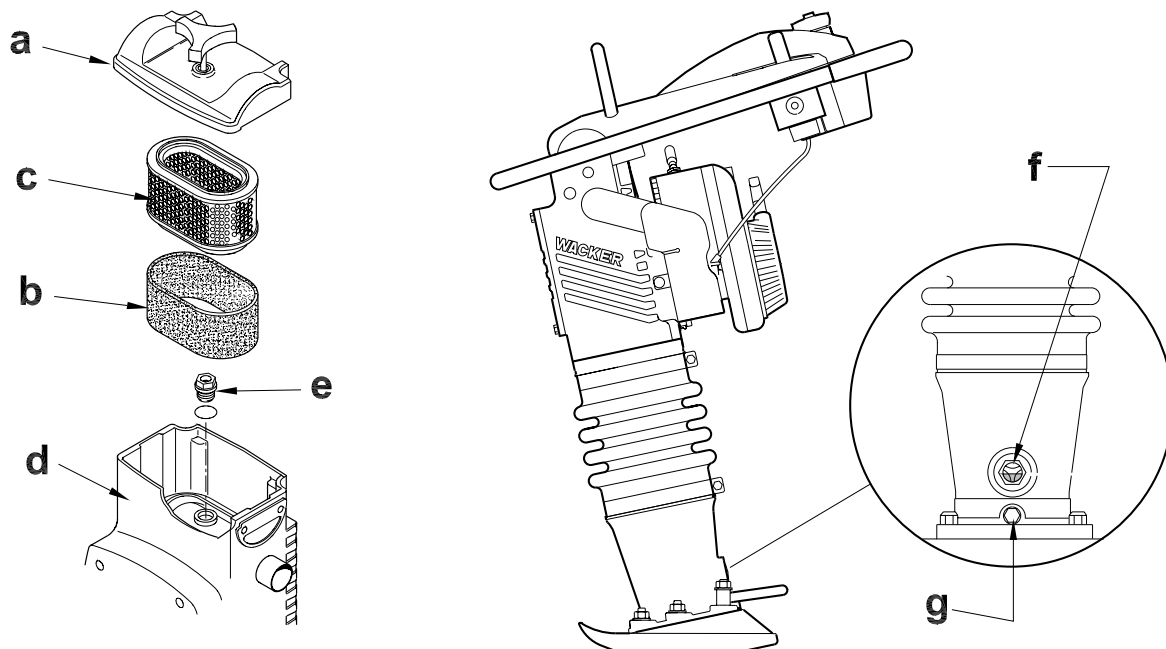

wc_gr000046

wc_gr000054

6.3 Lubrication

See Graphic: *wc_gr000054, wc_gr000046*

- 6.3.1 Change ramming system oil after first 50 hours of operation and every 300 hours thereafter. To drain oil, remove plug **(g)** and tilt machine back until it is resting on handle.

Note: *In the interests of environmental protection, place a plastic sheet and a container under the machine to collect any liquid which drains off. Dispose of this liquid in accordance with environmental protection legislation.*

- 6.3.2 With the rammer on a level surface, add oil through plug **(e)**. Proper ramming system lubrication is indicated when approximately 1/2-3/4 of the sightglass **(f)** is full.

6.4 Shoe Hardware

See Graphic: *wc_gr000055*

On new machines, or after replacing shoe, check and tighten shoe hardware **(a)** after the first 5 hours of operation. Inspect hardware every week thereafter.

Torque hardware as specified.

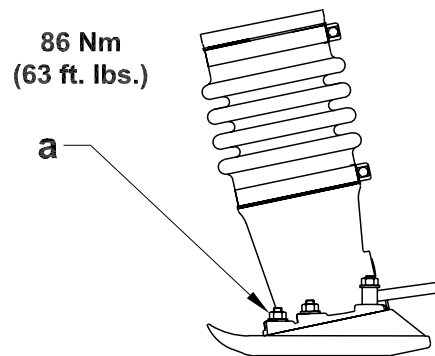

wc_gr000055

6.5 Carburetor Adjustments

See Graphic: *wc_gr000049*

Refer to *Technical Data* for correct idle and operating rpm. For best accuracy, use a tachometer when making carburetor adjustments.

- 6.5.1 Start engine and allow it to warm up to operating temperature.
- 6.5.2 Set engine idle speed with engine running at idle and choke **(a)** fully open. Adjust idle speed screw **(b)**, in or out, to obtain correct idle speed.

NOTICE: DO NOT turn the adjusting screw in too tight or you may damage the carburetor.

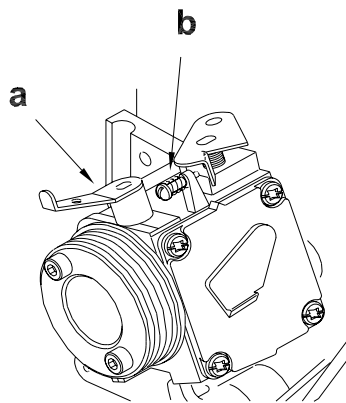

wc_gr000049

6.6 Storage

- 6.6.1 Drain fuel from tank.
- 6.6.2 Start engine and run until remaining fuel is used.
- 6.6.3 Remove spark plug. Pour approximately 30 ml (1 oz.) of clean SAE 10W30 engine oil into cylinder through spark plug opening.
- 6.6.4 Pull starter rope slowly to distribute oil in engine.
- 6.6.5 Re-install spark plug.

6.7 Transportation

See Graphic: *wc_gr000208*

- 6.7.1 Always shut off engine and close fuel valve when transporting machine.
- 6.7.2 Make sure lifting device has enough capacity to hold machine (see identification plate on machine for weight).
- 6.7.3 Use central lifting point **(a)** when lifting machine.



WARNING

Always inspect crane lifting cable for wear, damage, or abuse. Protect cable from any sharp edges. Do not use if there are any signs of cut wires, excessive wear, or other defects. Replace damaged cable immediately to avoid injury or death.

- 6.7.4 Tie down machine on vehicle to prevent it from tipping, falling, or rolling. Lay machine down flat and tie to vehicle at points **(a)** and **(b)**.

NOTICE: Drain fuel tank as required to prevent fuel leaking from cap **(c)**.

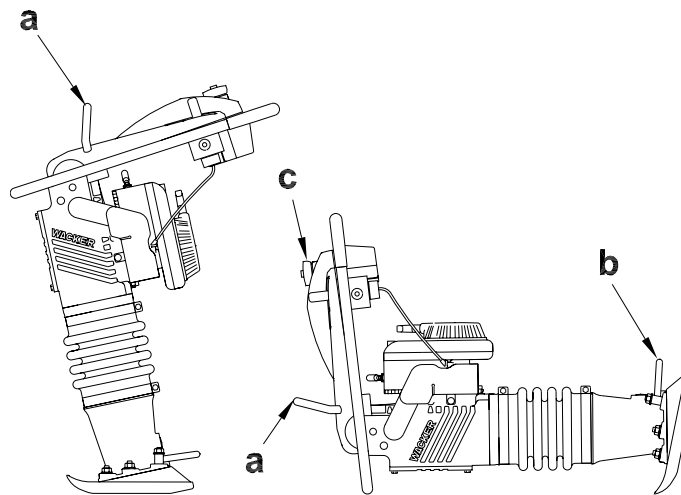

wc_gr000208

6.8 Troubleshooting

Problem / Symptom	Reason / Remedy
Engine does not start, or stalls.	<ul style="list-style-type: none"> • No fuel in tank. • Spark plug fouled. • Fuel valve closed.
Engine does not accelerate, is hard to start, or runs erratically.	<ul style="list-style-type: none"> • Improper fuel mix. Too much oil. • Spark plug fouled. • Clean muffler and exhaust port. • Crankshaft seals are leaking. • Check air cleaner.
Engine overheats.	<ul style="list-style-type: none"> • Improper fuel mix. Not enough oil. • Clean cooling fins and fan blades.
Engine runs, rammer does not tamp.	<ul style="list-style-type: none"> • Inspect clutch for damage. Replace if necessary. • Broken connecting rod or crankgear. • Low engine performance. Compression loss. Plugged exhaust port.
Engine runs, rammer operation is erratic.	<ul style="list-style-type: none"> • Oil/grease on clutch. • Broken/worn springs. • Soil buildup on ramming shoe. • Broken parts in ramming system or crankcase. • Engine operating speed is too high.

Notes

EC DECLARATION OF CONFORMITY
CE-KONFORMITÄTSERKLÄRUNG
DECLARACIÓN DE CONFORMIDAD DE LA CE
DÉCLARATION DE CONFORMITÉ C.E.

WACKER CORPORATION, N92 W15000 ANTHONY AVENUE, MENOMONEE FALLS, WISCONSIN USA

AUTHORIZED REPRESENTATIVE IN THE EUROPEAN UNION BEVOLLMÄCHTIGTER VERTRETER FÜR DIE EUROPÄISCHE GEMEINSCHAFT REPRESENTANTE AUTORIZADO EN LA UNIÓN EUROPEA REPRÉSENTANT AGRÉÉ AUPRÈS DE L'UNION EUROPÉENNE	WACKER CONSTRUCTION EQUIPMENT AG Preußenstraße 41 80809 München
---	---

hereby certifies that the construction equipment specified hereunder / bescheinigt, daß das Baugerät / certifica que la máquina de construcción / atteste que le matériel :

1. Category / Art / Categoría / Catégorie **Vibratory Rammers
Vibrationsstampfer
Apisonadoras Vibratorias
Pilonneuses Vibrantes**
2. Type - Typ - Tipo - Type **BS 600, BS 700**
3. Item number of equipment / Artikelnummer / Número de referencia de la máquina / Numéro de référence du matériel :
**0007551, 0008207, 0009076, 0009077, 0009166, 0009212, 0009262, 0009307
0008051, 0009079, 0009167, 0009308, 0009328**
4. Net installed power / absolute installierte Leistung / Potencia instalada neta / Puissance installée nette :

**BS 600 2,1kW
BS 700 2,3 kW**

Has been sound tested per Directive 2000/14/EC / In Übereinstimmung mit Richtlinie 2000/14/EG bewertet worden ist / Ha sido ensayado en conformidad con la norma 2000/14/CE / A été mis à l'épreuve conforme aux dispositions de la directive 2000/14/CEE :

Conformity Assessment Procedure / Konformitätsbewertungsverfahren / Procedimiento para ensayar conformidad / Procédé pour l'épreuve de conformité	Name and address of notified body / Bei folgender einbezogener Prüfstelle / Oficina matriculadora / Organisme agréé	Measured sound power level / Gemessener Schall- leistungspegel / Nivel de potencia acústica determinado / Niveau de puissance acoustique fixé	Guaranteed sound power level / Garantierter Schalleleistungspegel / Nivel de potencia acústica garantizado / Niveau de puissance acoustique garanti
Annex VIII / Anhang VIII Anexo VIII / Annexe VIII	BSI, 389 Chiswick High Road, London W4 4AL United Kingdom	104 dB(A)	108 dB(A)

and has been produced in accordance with the following standards:
und in Übereinstimmung mit folgenden Richtlinien hergestellt worden ist:
y ha sido fabricado en conformidad con las siguientes normas:
et a été produit conforme aux dispositions des directives européennes ci-après :

**2000/14/EC
89/336/EEC
98/37/EEC
EN 500-1
EN 500-4**

William Lahner *Greg Orzal*

William Lahner
Vice President of Engineering

Greg Orzal
Manager, Product Engineering

09.04.03

Date / Datum / Fecha / Date

WACKER CORPORATION

